

SURNAME ..... FIRST NAME .....

JUNIOR SCHOOL ..... SENIOR SCHOOL .....

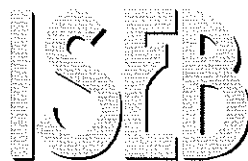

Independent Schools  
Examinations Board

## COMMON ENTRANCE EXAMINATION AT 13+

# SCIENCE

# PHYSICS

**Wednesday 9 November 2011**

Please read this information before the examination starts.

- This examination is 40 minutes long.
- The answers should be written on the question paper.
- Answer **all** the questions.
- Calculators may be required.



1. Underline the option which best completes each of the following:

(a) Fast-growing plants are a renewable energy resource called

**biomass**                      **coal**                      **nuclear**                      **oil**

(b) A space craft which is moving in space with no force acting on it will

**accelerate**                                      **move at a constant speed**  
**slow down**                                      **speed up**

(c) A unit of mass is the

**joule**                      **kilogramme**                      **newton**                      **second**

(d) When the frequency of a sound wave increases, the sound

**becomes higher pitched**                      **becomes lower pitched**  
**becomes quieter**                                      **sounds the same**

(e) The component in which the resistance decreases as the light intensity increases is a

**buzzer**                      **lamp**                      **LDR**                      **LED**

(f) The separation of colours by a prism is called

**dispersion**                      **frequency**                      **reflection**                      **refraction**

(6)

2. The circuit diagram below includes lamps and ammeters.

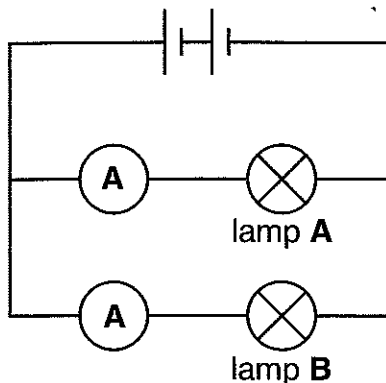

(a) State whether the lamps in the circuit above are in series or parallel.

..... (1)

(b) The ammeter next to lamp A reads 0.5 amps.

If the lamps are identical, what reading would you expect on the ammeter next to lamp B?

..... (1)

(c) (i) Mark on the diagram, with an X, where you would place a component to turn both lamps off. (1)

(ii) In the space below, draw the correct symbol for the component you have chosen.

(1)

Lamp A is now unscrewed.

(d) (i) State what, if anything, will happen to the brightness of lamp B.

..... (1)

(ii) Suggest a reason for this.

..... (1)

3. This question is about fuels and energy.

Some fuels are non-renewable.

(a) Explain what is meant by a fuel being *non-renewable*.

.....  
.....

(1)

In the UK we generate electricity from a range of sources which have changed over the years.

Study the pie charts below which show data for the years 2004 and 2008.

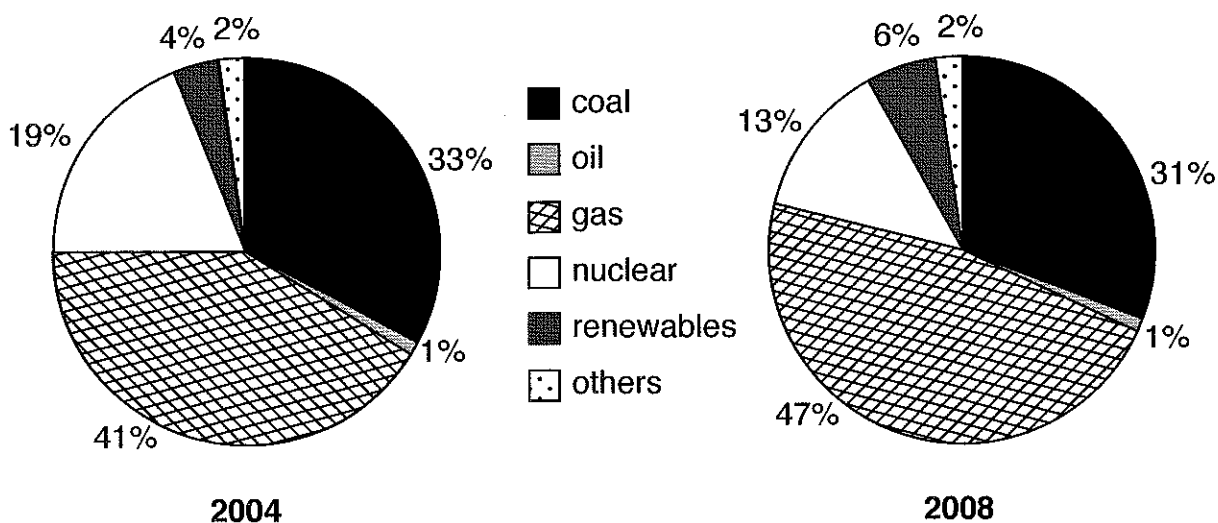

(b) (i) Describe how the UK's use of gas for generating electricity has changed during this time.

.....

(1)

(ii) Less coal was used to generate electricity in 2008 than in 2004.

State one advantage to the environment of this change.

.....

(1)

(iii) State two other main changes in the use of energy resources.

change 1: .....

.....

(1)

change 2: .....

.....

(1)

- (c) The energy in coal originally came from the Sun.  
Explain how this energy eventually became stored in coal.

.....  
.....  
.....

(2)

4. Light comes from sources such as the Sun, flames and lamps.

- (a) State the scientific name which is used to describe an object which gives out its own light.

.....

(1)

A lamp is placed in front of a mirror.

The diagram below shows three rays of light, **A**, **B** and **C**, from the lamp striking the mirror.

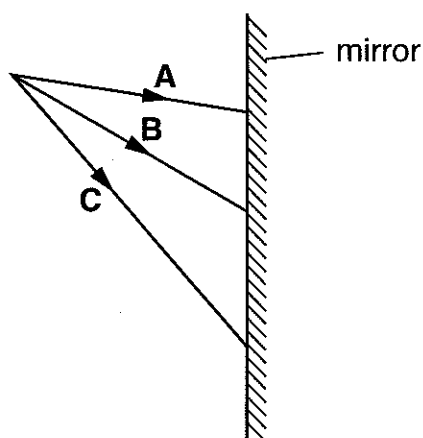

- (b) (i) Draw on the diagram to show how these rays reflect from the mirror. (2)  
(ii) State which of the rays makes the smallest angle of incidence at the mirror.

.....

(1)

5. This diagram shows a brick resting on its end:

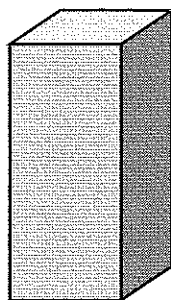

The brick has a mass of 2 kg.

The Earth's gravity exerts a force of 10 N on each kg.

(a) Calculate the weight of the brick.

Give the unit.

weight: ..... (1)

unit: ..... (1)

The area of the brick in contact with the ground is 40 cm<sup>2</sup>.

(b) (i) State the equation which relates pressure to force and area.

..... (1)

(ii) Calculate the pressure in N/cm<sup>2</sup> which the brick exerts on the ground.

.....  
..... (2)

The brick is now laid flat on the ground.

(c) (i) State whether the pressure on the ground will increase, decrease or stay the same.

..... (1)

(ii) Explain your answer.

.....  
..... (1)

6. The diagram below shows a few of the planets in our solar system orbiting the Sun.

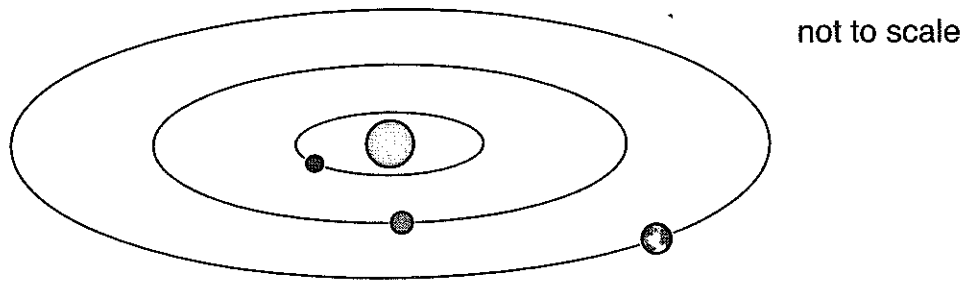

On a clear night, some of the planets can be seen from Earth at certain times of the year.

(a) Explain how it is possible to see planets even though they do not give out their own light.

.....  
..... (2)

(b) Explain why there are some times of the year when it is not possible to see Mars, even on a clear night.

.....  
.....  
..... (2)

(c) Suggest why it is not possible to see Neptune with the naked eye on any night.

..... (1)

(d) Many man-made satellites orbit the Earth.  
State the name of the only natural satellite of the Earth.

..... (1)

7. Harry measured how much a spring stretched when masses were added to it. He recorded his results in a table. This is a diagram of his apparatus:

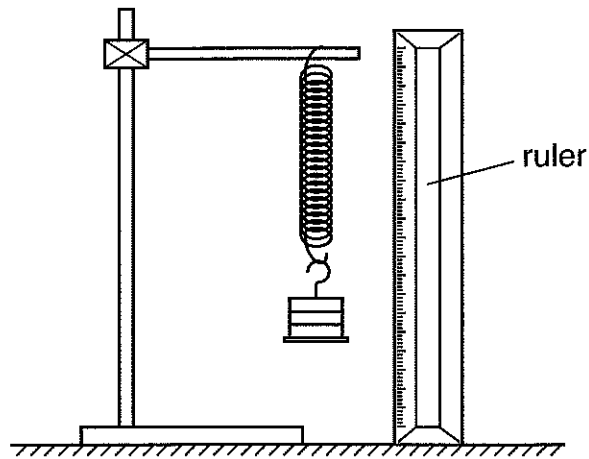

Here is his table of results:

mass, in g	length of spring, in cm	extension of spring, in cm
0	2.5	0
100	4.3	1.8
200	6.1	
300	6.5	4.0
400	10.1	
500	11.7	9.2

- (a) Complete the third column of the table to show the extension of the spring. (2)



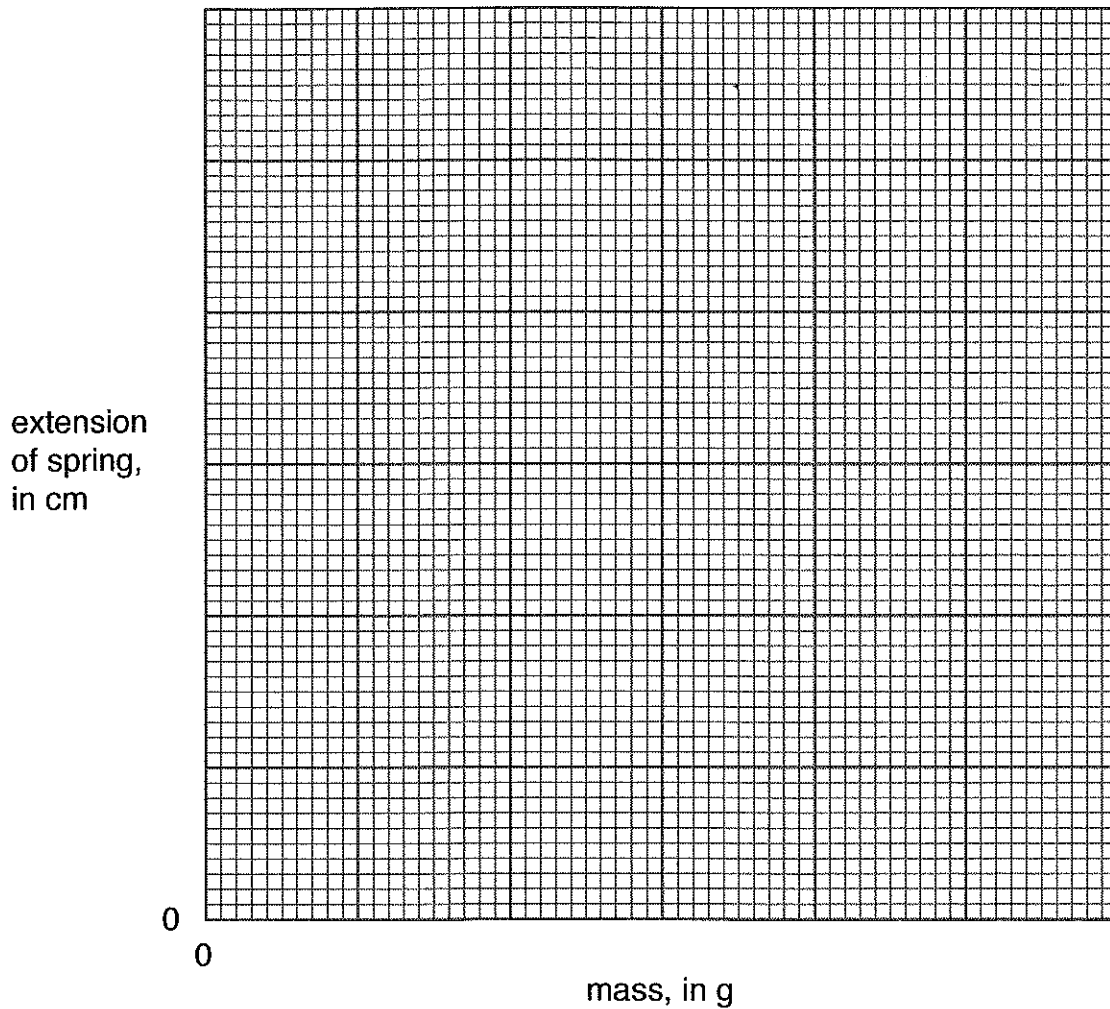

(b) On the graph grid above,

- (i) add suitable scales to both axes; (1)
- (ii) plot the extension of the spring against the mass. (2)

Harry thinks that one of his data points is anomalous.

- (c) (i) Circle the anomalous point. (1)
- (ii) Draw a best fit, straight line through the data points. (1)
- (iii) Suggest a mistake which Harry made which could have caused the anomalous point.

.....  
 ..... (1)

(iv) Explain how Harry could check the reliability of this anomalous result.

.....  
 ..... (1)

8. Lucy and Sam want to check the speed of cars outside their school. They make two marks 50 metres apart at the side of the road. Lucy stands beside one mark and Sam stands beside the other. Lucy stands beside one mark and Sam stands beside the other.

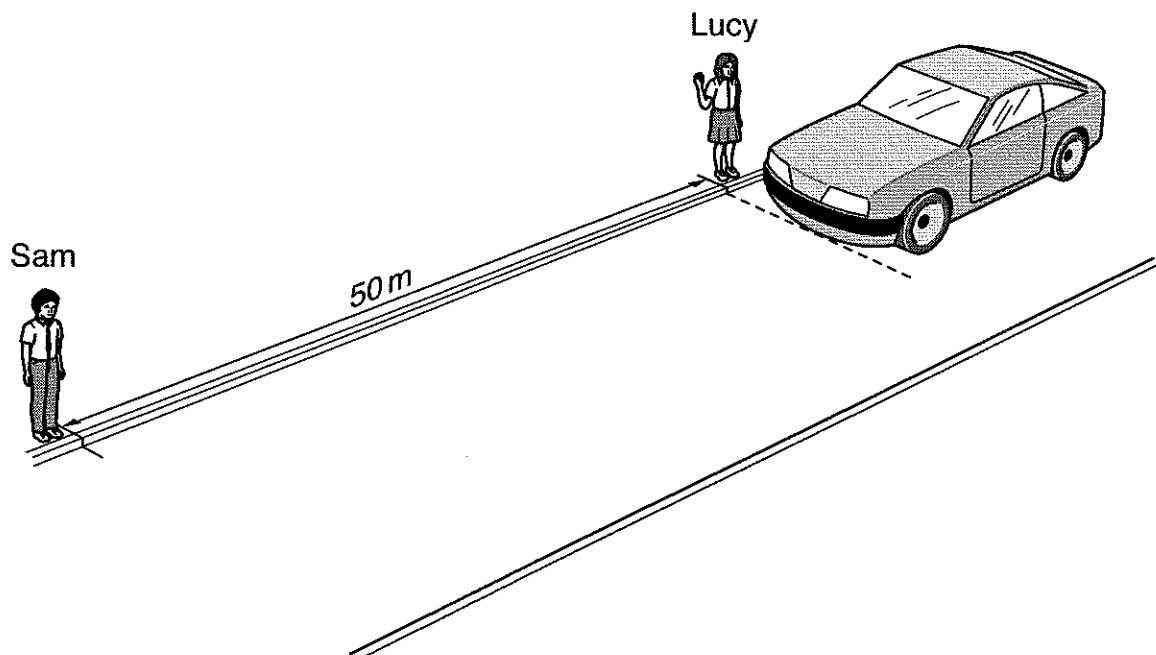

Lucy raises her arm to signal when a car passes the first mark.

Sam starts a stopwatch when he sees Lucy signal and stops it when the car reaches his mark.

- (a) State the equation which relates speed to distance and time.

..... (1)

- (b) Sam finds that it takes one car 4.5 s to travel the 50 m. Calculate its speed, giving the correct unit.

.....  
..... (2)

(c) The speed limit outside the school is 20 miles per hour.

This is equivalent to 9 m/s.

Sam says that this means that the driver was breaking the speed limit but Lucy says that his measurement of the time is probably too short.

(i) Explain why Sam's measurement of the time may have been too short.

.....  
.....  
.....

(2)

(ii) Does this mean that the car was probably going faster or more slowly than your answer to (b)?

.....

(1)

9. (a) Underline one word in each box below to complete the following statement about levers.

For a lever to 

balance
tip

 the clockwise and anticlockwise 

moments
forces

 must be equal.

(2)

Rosie weighs 600 N and Jim weighs 450 N.

They sit on either side of a seesaw.

Rosie is 1.5 m from the pivot and Jim is 1.8 m from the pivot.

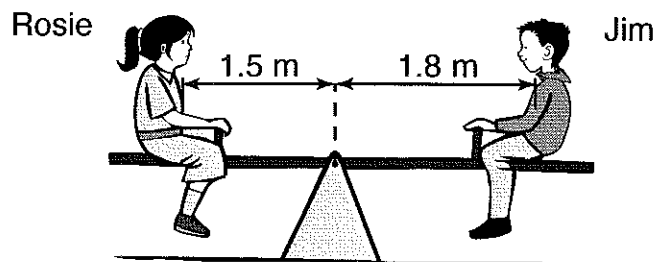

(b) Do a calculation to decide whether the seesaw is balanced.

If it is not balanced, state which way it will tip.

Show your working clearly.

.....  
.....  
.....  
.....

(3)

10. Jenny places a bar magnet under a piece of paper.  
 She sprinkles some iron filings over the paper.  
 Then she taps the paper.  
 The diagram below shows the paper seen from above.  
 The outline of the magnet under the paper is shown.

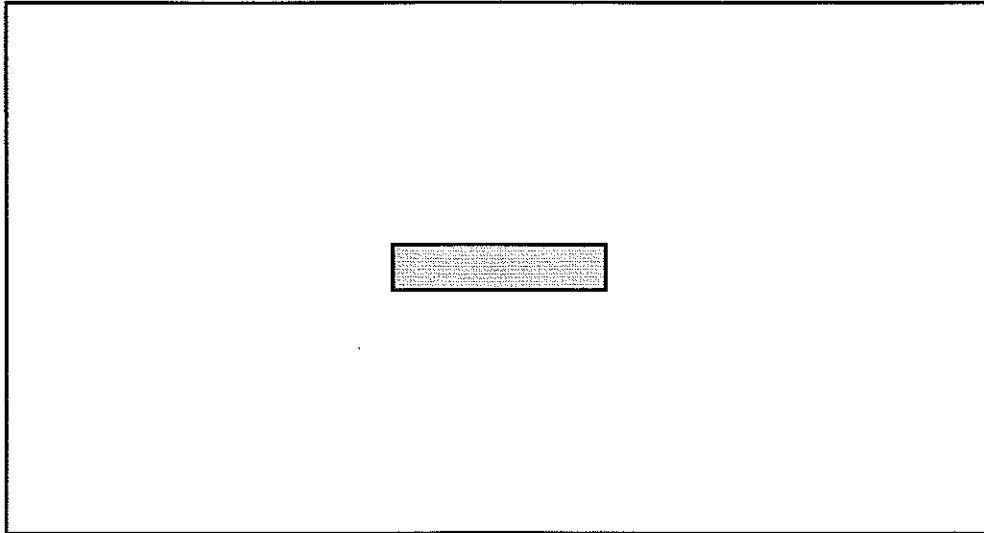

(a) Draw on the diagram to show the pattern the iron filings will make. (1)

(b) Suggest why Jenny taps the paper after she has sprinkled the iron filings over it.

.....  
 ..... (1)

(c) Jenny replaces the bar magnet with an electromagnet.

State two things which she could do to make her electromagnet as strong as possible.

1: .....  
 ..... (1)

2: .....  
 ..... (1)

(Total marks: 60)